

Flow-Thru™ Plus Inline Adapters

Anti-legionella solutions

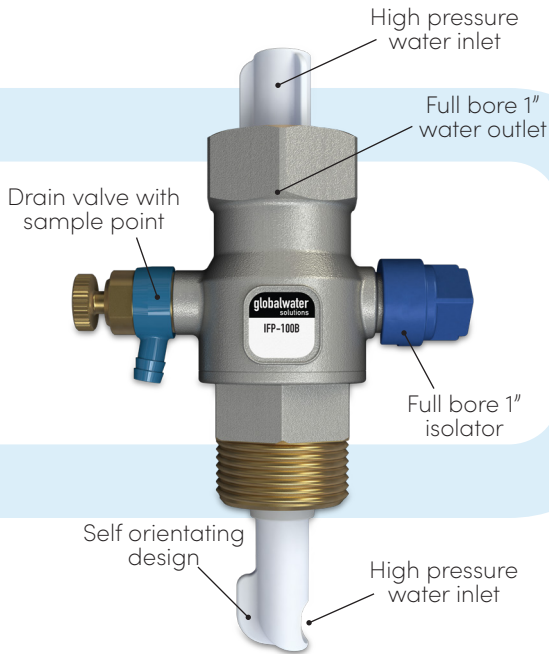

Features

- Patent pending Flow-Thru™ Technology eliminates stagnant water, which stops the colonization of microbes in expansion tanks including Legionella
- Ensures the freshest water in the tank
- Reduces the risk of water-borne diseases
- Self-orientating design scoop allows for multiple installation positions, it eliminates the risk of leaking or overtightened connections
- 1" Connection offering superior fresh water exchanges compared to other 3/4" designs
- The Plus Version (IFP-100B/IFP-100N version) includes isolation, drain and water sample point, allowing easy servicing, maintenance and conforms to HSG274pt2 and ECDC EU recommendations
- Compatible with Global Water Solutions inline tanks
- Includes the unique "auto alignment scoop" which guarantees the correct positioning of the Flow-Thru system

Global Water Solutions' Flow-Thru™ Plus inline adapters are ideally suited for continuous pressure systems where there is a risk of stagnant water in the tank. The Flow-Thru Plus inline adapter diverts the water through the tank while the water is running, eliminating the risk of stagnant water and reducing the risk of waterborne bacteria such as legionella. This constant flushing ensures the freshest water in the tank.

Flow-Thru Plus inline adapters are 1" full bore recirculation devices that offer superior flow rates compared to other 3/4" devices. Their unique design provides maximum circulation in the tank whilst assuring minimal pressure drop in the main pipe.

Flow-Thru™ Plus Inline Adapter

- Self-orientating design eliminates the risk of leaking or overtightened connections.
- Isolation valve allows for easy expansion tank servicing.
- Built in drain valve to allow full service and maintenance of the expansion tank without disruption to water supply.
- Prevents stagnant water on booster sets.

Models

| Model Number | Connection |
|--------------------------|--------------|
| IFA-100BSP / IFA-100NPT* | 1" BSP / NPT |
| IFP-100B / IFP-100N | 1" BSP / NPT |

The maximum temperature of the Flow-Thru Plus adapter is 90°C / 194 °F

*Limited stocks, ask your representative

Easy servicing and maintenance

The IFP-100B and IFP-100N Flow-Thru Plus Inline Adapter come with the built-in drain and isolation valves. The drain valve allows for easy sampling of the water for quality checks while the isolating valve allows servicing and maintenance of the expansion vessel. All without any disruption to the water supply.

Legionnaires' disease

Legionnaires' disease is a severe form of pneumonia caused by legionella bacteria. Legionella is found naturally in fresh water and can become a health concern when it grows and spreads in water systems. Contamination usually happens through breathing in aerosols derived from small droplets of water that contain the bacteria (aspiration is another route especially in stroke and elderly patients or those with any illness that affects the swallowing reflex).

Prevention of Legionnaires' disease

European guidelines such as the "European Technical Guidelines for the Prevention, Control and Investigation, of Infections Caused by Legionella species" and "HSG274pt2" recognize the risk of "expansion vessels in systems operating at steady temperature and pressure". Recommendations are made to use devices "designed to stimulate flow within the vessel" and to install expansion vessels in a cool place "with an isolation and drain valve to aid flushing and sampling".

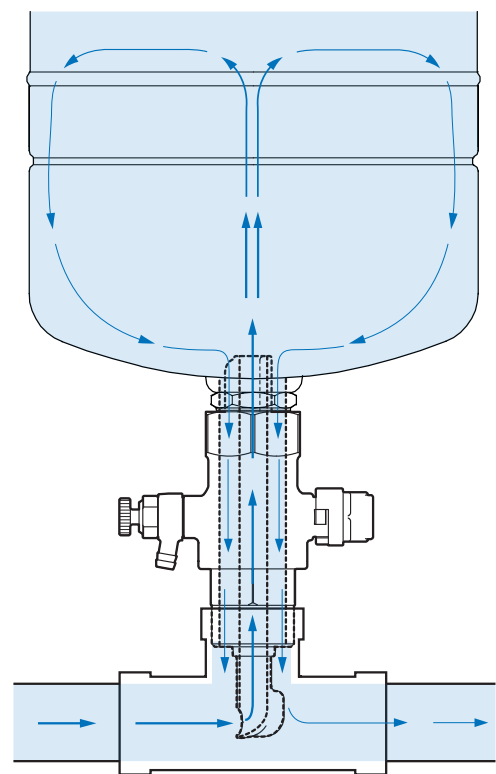

The European Guidelines Working Group. European Technical Guidelines for the Prevention, Control and Investigation, of Infections Caused by Legionella Species. By Dr Susanne Lee et al. 2017. p83.